

# Exterior Brackets

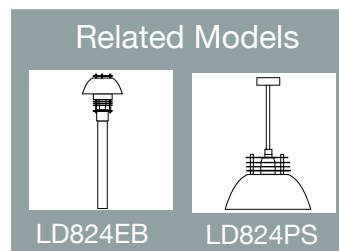

LD824EW-HGS  
Hot Dipped  
Galvanized Steel

*The outdoor version of the LD824 series. This unit comes in hot dipped galvanized steel. The galvanizing leaves an intriguing random finish that varies from smooth to crystalline. The zinc weathers to a soft gray over time. Available with custom painted finishes over the galvanized for a durable coloured finish.*



# Technical Specifications

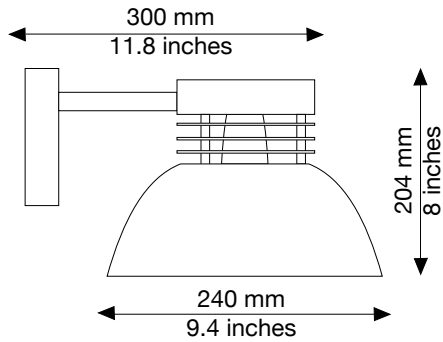

## Lamping for Hardwiring (HW)

Source	Ballast	Voltages	Restrictions
Inc 60W max.	none	120	
CFL up to 26W	electronic	All Voltages	Required 2" x 6", Wall Box
Metal Halide 20W or 39W	electronic	120, 277	Requires 2" x 6", Wall Box

### Colours:

Hot Dipped Galvanized Steel-HGS

Custom/Colour (See options on page 3, specify requirements at time of quotation for accurate pricing)

Custom Paint is applied over the Hot Galvanized Steel-CC

### Part Number Example:

**LD-824EW** Exterior Wall, Custom Paint RAL 4001, Compact Fluorescent 26W, 277 Volts.

Part number as follows:

LD-824EW-CC-CF26W-277-RAL 4001

MODEL	—	824EW	CC	CF26W	277	RAL 4001
COLOUR	_____	_____	_____	_____	_____	_____
SOURCE	_____	_____	_____	_____	_____	_____
VOLTAGE	_____	_____	_____	_____	_____	_____
Custom	_____	_____	_____	_____	_____	_____
Colour	_____	_____	_____	_____	_____	_____

See [www.laternadanica.ca](http://www.laternadanica.ca) for current specifications